

B-Tronic EasyControl EC5401B

en

Assembly and Operating Instructions

Wall/hand-held transmitter, 1-channel, bidirectional

Important information for:

- Fitters / • Electricians / • Users

Please forward accordingly!

These instructions must be kept safe for future reference.



4035 630 003 0f 05/12/2018



Table of contents

General	3
Warranty	3
Safety instructions	4
Intended use	5
Explanation of displays and buttons	6
Normal/master mode	8
Programming the first transmitter	9
Querying/Changing the receiver mode	10
Programming more transmitters	12
Deleting transmitters	14
Changing the direction of rotation of B-Tronic products	16
Setting the limit positions of B-Tronic tubular drives	17
Upper stop to lower stop	17
Upper point to lower point	18
Upper stop to lower point	19
Upper point to lower stop	19
Deleting the limit positions of B-Tronic tubular drives	20
Performing the programming run on B-Tronic radio receivers	21
Deleting the programming run on B-Tronic radio receivers	22
Intermediate positions/tilt positions	23
Memory function	25
Upper anti-freeze mechanism	26
Activating/Deactivating upper anti-freeze mechanism	27
Fly screen protection function	27
Activating/deactivating repeater mode	28
Reset the transmitter to the factory setting	29
Clean-up function for B-Tronic products	30
Changing batteries	31
Wall bracket	32
Cleaning	32
Technical data	33
What to do if...?	33
Simplified EU declaration of conformity	34



General

You can operate drives and control units with bidirectional KNX radio with this transmitter.

This device is exceptionally easy to use.

Please observe these Assembly and Operating Instructions when installing and setting up the equipment.

Explanation of pictograms

	CAUTION	CAUTION indicates a hazardous situation which, if not avoided, could result in injury.
	ATTENTION	ATTENTION indicates measures that must be taken to avoid damage to property.
		Denotes user tips and other useful information.

You will find the current status on the type plate according to the following symbol: 

The description of the acknowledgement can be found in the relevant instructions for the receiver.

Warranty

Structural modifications and incorrect installation which are not in accordance with these and our other instructions can result in serious injuries, e.g., crushing of limbs. Therefore, structural modifications may only be carried out with our prior approval and strictly in accordance with our instructions, particularly the information contained in these Assembly and Operating Instructions.

Any further processing of the products which does not comply with their intended use is not permitted.

The end product manufacturer and fitter have to ensure that all the relevant current statutory, official and, in particular, EMC regulations are adhered to during utilisation of our products, especially with regard to end product manufacture, installation and customer advice.

Safety instructions

General information

- Please keep the instructions safe!
- Only use in dry rooms.
- Only use unmodified original parts from the control unit manufacturer.
- Keep children away from control units.
- Observe all pertinent country-specific regulations.
- Dispose of exhausted batteries properly. Only replace batteries with the identical type (see Technical data).



Caution

- **Keep people out of the system's range of travel.**
- **If the system is controlled by one or more transmitters, the system's range of travel must always be visible during operation.**
- **Device contains small parts that can be swallowed.**

Intended use

The transmitter described in these instructions may only be used for operating suitable drives and control units with bidirectional KNX radio. You can operate either one group or a number of groups of devices with this transmitter.

- Please note that radio-controlled systems may not be used in areas with a high risk of interference (e.g. hospitals, airports).
- The remote control is intended solely for use with equipment and systems in which malfunctions in the transmitter or receiver would not pose any risk to persons, animals or property, or which contain safety devices to eliminate such risks.
- The operator is not protected from interference from other telecommunications systems and terminal equipment (e.g. even from radio-controlled systems which are properly operated in the same frequency range).
- Only connect radio receivers to devices and systems approved by the manufacturer.



- **Ensure that the control unit is not installed or operated close to metal surfaces or magnetic fields.**
- **Radio-controlled systems transmitting on the same frequency may cause reception interference.**
- **Note that the range of the radio signal is limited by legislation as well as by design.**

Explanation of displays and buttons

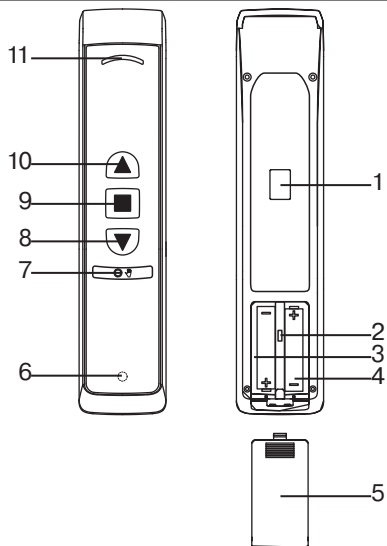

1 Wall bracket receptacle

2 Master button 

3 Type plate

4 Batteries

5 Battery compartment cover

6 Programming button  (behind the logo)

7 Changeover switch 

8 DOWN button 

9 STOP button 

10 UP button 

11 Status LED 

Functional overview of the control buttons UP (▲), STOP (■), DOWN (▼)

Function	Button actuation	Button actuation												
		UP	STOP	DOWN	Touch mode UP	Touch mode DOWN	ON	OFF	Intermediate position I* ¹	Intermediate position II* ¹	Tilt position I* ¹	Tilt position II* ¹	STOP/STEP* ²	
Roller shutter	<1s	▲	■	▼	▲	▼								
	>1s	▲	■	▼										
Screen	<1s	▲	■	▼				▲	▼	▲	▼			
	>1s	▲	■	▼										
Blind	<1s				▲	▼		▲	▼	▲	▼	▲	▼	■
	>1s	▲		▼										■
Roof window	<1s	▲	■	▼				▲	▼	▲	▼			
	>1s	▲	■	▼										
ON/OFF	<1s						▲	▼	■					
	>1s						▲	▼	■					
Pulse	<1s						▲	▼	■					
	>1s						▲	▼	■					

*¹) If present.

*²) With a STOP command, the STEP is always made in the UP direction



Normal/master mode

The transmitter can be operated in two modes:

- **Normal mode** (normal operation) The commands that are issued apply to **all** the receivers of a channel.
- **Master mode** (Setting mode for all B-Tronic products) The commands issued apply exclusively to **one** selected receiver of a channel.

The normal mode is set at the factory.

Activating master mode

Press the master button  until the changeover button  flashes green once per second. This flashing will continue as long as you remain in master mode.

By pressing the master button again, the programmed receiver is selected, or the programmed receivers are selected in sequence.

The selected receiver confirms.

You can now make the various settings that are only available in master mode. When all the desired settings have been made at this receiver, you can press the master button again to select the next receiver for programming.

Leaving master mode

There are two ways to leave master mode:

1. Press the changeover button 
2. Master mode is automatically closed once 2 minutes have gone by without a button being pushed

Programming the first transmitter



The receiver mode must always be set appropriately for the receiver. Roller shutter/venetian blind is the factory setting.

Putting the receiver into programming mode



Follow the Assembly and Operating Instructions for the receiver.

- Switch off the power supply to the receiver for 5 seconds, then switch it back on

or

- Operate the programming button or the radio switch of the receiver.

The receiver is now in programming mode for 3 minutes.

Programming transmitters



Please make sure that only one receiver is in programming mode at any time. It is not possible to program/clear multiple receivers at the same time.

Press the transmitter's programming button while programming mode is active, until the receiver confirms successful programming. The status LED flashes yellow during the programming process.

The programming process is now complete.

	Lights up green / red	Action completed successfully (green) or not successfully (red).
---	-----------------------	--





Querying/Changing the receiver mode



The receiver mode must always be set appropriately for the receiver. Roller shutter/venetian blind is the factory setting.

Querying the current receiver mode



There are different receiver modes. The receiver mode must always be set appropriately for the receiver (e.g. roller shutter/blind, dimmer/switch). Roller shutter/venetian blind is the factory setting.

  		Briefly press the programming button, and then the changeover button for 1 second.
	Flashes yellow once	Receiver mode roller shutter
	Flashes yellow twice	Receiver mode dimmer
	Flashes yellow three times	Receiver mode switch
	Flashes yellow four times	Receiver mode venetian blind
	Flashes yellow five times	Receiver mode screen
	Flashes yellow six times	Receiver mode roof window

Changing to the desired receiver mode



The current receiver mode is first indicated through the display code.

 		Briefly press the programming button, and then the changeover button for 5 seconds.
	Flashes yellow once	Receiver mode roller shutter
	Flashes yellow twice	Receiver mode dimmer
	Flashes yellow three times	Receiver mode switch
	Flashes yellow four times	Receiver mode venetian blind
	Flashes yellow five times	Receiver mode screen
	Flashes yellow six times	Receiver mode roof window

Repeat this procedure until the desired receiver mode has been selected.

Programming more transmitters



The receiver mode must always be set appropriately for the receiver. Roller shutter/venetian blind is the factory setting.

Programming more B-Tronic transmitters in the B-Tronic receiver

Put the receiver into programming mode in one of the three possible ways.



Please make sure that only one receiver is in programming mode at any time. It is not possible to program/clear multiple receivers at the same time.

Putting the B-Tronic receiver into programming mode with a programmed B-Tronic transmitter

Put the transmitter into master mode.

Select the receiver by pressing the  button until the desired receiver confirms.

All the following settings will then only be executed for this device.



Press the programming button of the programmed transmitter.

- The receiver confirms.
- ▶ The receiver goes into the programming mode for 3 minutes



Putting the B-Tronic receiver into programming mode by switching on the power

Switch on the power.

- ▶ The receiver goes into the programming mode for 3 minutes

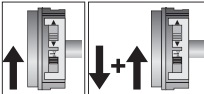
	<p>Putting the B-Tronic receiver into programming mode with the radio switch</p> <p>Switch the radio switch to the inside position. If the radio switch is already in this position, switch it to the outside and back to the inside position.</p> <ul style="list-style-type: none"> ▶ The tubular drive goes into the programming mode for 3 minutes
	<p>Press the programming button for 3 seconds.</p> <p>The LED flashes green.</p> <ul style="list-style-type: none"> ▶ The receiver goes into the programming mode for 3 minutes

When the receiver is in programming mode, proceed as follows:

	<p>Now press the programming button of the new transmitter.</p> <ul style="list-style-type: none"> ▶ The receiver confirms. ▶ The programming process is now complete.
---	--

	<p>Lights up green / red</p>	<p>Action completed successfully (green) or not successfully (red).</p>
---	------------------------------	---

Programming more B-Tronic transmitters in a KNX RF compatible receiver from another manufacturer

Please find the appropriate description on our website.

Programming more KNX RF compatible transmitters from another manufacturer in a B-Tronic receiver

Please find the appropriate description on our website.







Deleting transmitters

Deleting from B-Tronic receivers with two B-Tronic transmitters

Put a programmed transmitter, other than the one that is to be deleted, into master mode.

Select the device by pressing the  button until the desired device confirms.











All the following settings will then only be executed for this device.

		While the transmitter is in master mode, the symbols on the changeover button flash green once per second.
	 Changes from green to yellow	Now press the programming button, until the status LED changes from green to yellow, and the receiver confirms.
	 Flashes yellow	Press the programming button, until the status LED flashes yellow and the receiver confirms.
		Now press the programming button of the transmitter to be deleted until the receiver confirms. <ul style="list-style-type: none">▶ The transmitter is now deleted from the receiver.
	Lights up green / red	Action completed successfully (green) or not successfully (red).

Deleting from B-Tronic receivers with one B-Tronic transmitter



The last or only transmitter in a receiver can be deleted using the following deletion sequence. To program new transmitters, the receiver must again be put into programming mode.

Put the transmitter into master mode.		
Select the device by pressing the  button until the desired device confirms. All the following settings will then only be executed for this device.		
		While the transmitter is in master mode, the symbols on the changeover button flash green once per second.
	 →  Changes from green to yellow	Now press the programming button, until the status LED changes from green to yellow, and the receiver confirms.
	 Flashes yellow	Press the programming button, until the status LED flashes yellow and the receiver confirms.
		Now press the changeover button to leave master mode.
		Now press the programming button until the receiver confirms. ▶ The transmitter is now deleted from the receiver.
	Lights up green / red	Action completed successfully (green) or not successfully (red).



Deleting a B-Tronic transmitter from a KNX RF compatible receiver from another manufacturer

Please find the appropriate description in the instructions for the receiver or on our website.

Changing the direction of rotation of B-Tronic products

Check the direction of rotation before setting the limit positions. The shading solution must move in the correct direction when the UP or DOWN buttons are pressed.

If this is not the case, please carry out the following steps to change the direction of rotation:

No limit positions must be programmed. Delete the limit positions if necessary.	
Put the transmitter into master mode.	
Select the receiver by pressing the  button until the desired receiver confirms.	
	<p>First press the programming button and, within the next 3 seconds, press both the UP and DOWN buttons for 3 seconds.</p> <p>▷ The receiver confirms.</p> <p>Check the running direction again.</p>

Setting the limit positions of B-Tronic tubular drives

Upper stop to lower stop

Put the transmitter into master mode.

Select the tubular drive by pressing the  button until the tubular drive confirms.

All the following settings will then only be executed for this device.

▲	Open to the permanent upper stop. <ul style="list-style-type: none">▷ The tubular drive switches off automatically.
▼	Then close to the permanent lower stop. <ul style="list-style-type: none">▷ The tubular drive switches off automatically.▶ The limit positions are now set.

Upper point to lower point

Put the transmitter into master mode.

Select the tubular drive by pressing the  button until the tubular drive confirms.

All the following settings will then only be executed for this device.

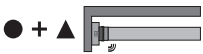
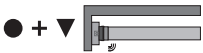

There is no shading solution length adjustment with this limit position setting.

▲	Open to the desired upper limit position.
	Press the programming button and, within 1 second, also press the UP button and hold the two buttons down. ▷ The receiver confirms.
▼	Then close to the desired lower limit position.
	Press the programming button and, within 1 second, also press the DOWN button and hold the two buttons down. ▷ The receiver confirms. ▶ The limit positions are now set.

Upper stop to lower point

Put the transmitter into master mode.

Select the tubular drive by pressing the **M** button until the tubular drive confirms.

All the following settings will then only be executed for this device.

▲	Open to the permanent upper stop. <ul style="list-style-type: none">▷ The tubular drive switches off automatically.
▼	Then close to the desired lower limit position.
 ● + ▼	Press the programming button and, within 1 second, also press the DOWN button and hold the two buttons down. <ul style="list-style-type: none">▷ The receiver confirms.▶ The limit positions are now set.

Upper point to lower stop

Put the transmitter into master mode.

Select the tubular drive by pressing the **M** button until the tubular drive confirms.

All the following settings will then only be executed for this device.

▲	Open to the desired upper limit position.
 ● + ▲	Press the programming button and, within 1 second, also press the UP button and hold the two buttons down. <ul style="list-style-type: none">▷ The receiver confirms.
▼	Then close to the permanent lower stop. <ul style="list-style-type: none">▷ The tubular drive switches off automatically.▶ The limit positions are now set.

Deleting the limit positions of B-Tronic tubular drives

Attention

When one or both of the limit positions are deleted, all the other set functions (e.g. intermediate position) are deleted as well.





Once set, the limit positions can only be deleted using master mode. Deleted limit positions are displayed on the limit position status indicator.

Deleting individual limit positions

Put the transmitter into master mode.

Select the tubular drive by pressing the  button until the tubular drive confirms.

All the following settings will then only be executed for this device.

	Open/close to the limit position to be deleted.
	<p>Press the programming button and, within the next 1 second, press the STOP button at the same time and hold the two buttons down for 5 seconds.</p> <ul style="list-style-type: none">▷ The receiver confirms.▶ The limit position is now deleted.

Deleting both limit positions

Put the transmitter into master mode.

Select the tubular drive by pressing the  button until the tubular drive confirms.

All the following settings will then only be executed for this device.

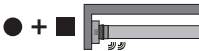
	Open/close the shading solution to a point between the limit positions.
	Press the programming button and, within 1 second, press the STOP button at the same time and hold the two buttons down for 5 seconds. <ul style="list-style-type: none">▷ The receiver confirms.▶ The limit positions are now deleted.

Performing the programming run on B-Tronic radio receivers





Feedback is disabled and it is not possible to program the intermediate positions until the programming run has been performed.

Put the transmitter into master mode.

Select the receiver by pressing the  button until the required receiver confirms.

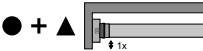
All the following settings will then only be executed for this device.

	Open to the desired upper limit position.
	Press the programming button and, within 1 second, also press the UP button and hold the two buttons down. <ul style="list-style-type: none">▷ The receiver confirms.
	Then close to the desired lower limit position.

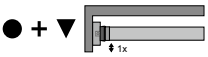
	<p>Press the programming button and, within 1 second, also press the DOWN button and hold the two buttons down.</p> <ul style="list-style-type: none"> ▷ The receiver confirms. ▶ The programming run is completed.
---	---

Deleting the programming run on B-Tronic radio receivers

Put the transmitter into master mode.

Select the receiver by pressing the  button until the required receiver confirms.

All the following settings will then only be executed for this device.

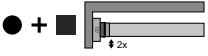
	<p>Open/close the shading solution to a point between the limit positions.</p>
	<p>Press the programming button and, within the next 1 second, press the STOP button at the same time and hold the two buttons down for 5 seconds.</p> <ul style="list-style-type: none"> ▷ The receiver confirms. ▶ The programming run is now deleted.

Intermediate positions/tilt positions





The intermediate positions or tilt positions are freely selectable positions for the shading solution or blind between the two limit positions. Each travel button can be assigned one intermediate position/tilt position. Both limit positions must be set before an intermediate position is set.



When both or individual limit positions are deleted, both intermediate positions/tilt positions are deleted as well.

With external receivers it is possible to overwrite in any position without deleting the previous position.

Setting the desired intermediate position

	Open/close the shading solution to the desired intermediate position.
	Press the STOP button and, within 3 seconds, also press the desired travel button and hold the two buttons down. <ul style="list-style-type: none">▷ The receiver confirms.▶ The intermediate position is now saved.

Setting the desired tilt position when operating blinds

	Move the blind from the upper limit position to the position at which you wish to attach the tilt.
	Press the STOP button repeatedly until the desired tilt position is reached.
	Press the STOP button and, within 3 seconds, also press the desired travel button and hold the two buttons down. <ul style="list-style-type: none">▷ The receiver confirms.▶ The tilt position is now saved.

Travelling to the desired intermediate position/tilt position

$2x \blacktriangle / 2x \blacktriangledown$	<p>Press the travel button for the desired intermediate position/tilt position twice within one second.</p> <ul style="list-style-type: none">▶ The shading solution runs to the intermediate position/tilt position assigned to the travel button.
	<p>Lights up green / red</p> <p>Action successful with all receivers (green) or not successful with at least one receiver (red).</p>

Deleting the desired intermediate position/tilt position



$2x \blacktriangle / 2x \blacktriangledown$	<p>Press the travel button for the desired intermediate position/tilt position twice within one second.</p> <ul style="list-style-type: none">▶ The shading solution runs to the intermediate position/tilt position assigned to the travel button.
	<p>Press the STOP button and, within 3 seconds, also press the travel button assigned to the intermediate position/tilt position and hold the two buttons down.</p> <ul style="list-style-type: none">▶ The receiver confirms.▶ The intermediate position/tilt position is now deleted.

Memory function



Every B-Tronic radio receiver for roller shutter and blind installations can save switching times for UP and DOWN movement.

In the "O" operating mode, this movement is repeated every 24 hours.

It does not matter what position the /O changeover button is in when programming the switching time. Previously stored switching times are overwritten.

	Lights up green	Roller shutter/all roller shutters are in automatic mode
	Lights up green	Roller shutter/all roller shutters are in manual mode
	Light up green	Roller shutters are in different modes



Switching from the "O" operating mode to the  operating mode must take place via the device on which the automatic command was programmed. If automatic commands have been programmed by several devices independently, they have to be changed to  separately.

Programming the run times

1. The tubular drive must be in the upper limit position to program the DOWN run time, and must be in the lower limit position for the UP run time.
2. Wait for the time you wish the automatic drive command to be executed.
3. At the desired time, press and hold the relevant direction button until the tubular drive briefly stops after approx. 6 seconds and then continues to the limit position.
4. Release the direction button.

The tubular drive has saved the current time for this direction of travel. Proceed in exactly the same way with the other direction of movement.

Deleting the run times



When deleting, both run times are always deleted.

To delete the UP and DOWN run time, press the STOP button for 10 seconds. The receiver confirms. The run times are now deleted.

Upper anti-freeze mechanism

The upper anti-freeze mechanism (if present in the receiver) helps to prevent the roller shutter from freezing in the upper limit position, as the roller shutter stops just before the upper stop. The distance from the upper stop is automatically cyclically checked and, if necessary, corrected.

The upper anti-freeze mechanism is deactivated on delivery.

Both limit positions must be set before the anti-freeze mechanism can be activated.



The anti-freeze mechanism only works if a permanent stop is set at the upper limit position of the roller shutter. The anti-freeze mechanism is not visible until the shading solution has reached the upper stop from the lower limit position 3 times in succession.



When both or individual limit positions are deleted, this set function is deleted as well.

Activating/Deactivating upper anti-freeze mechanism

Put the transmitter into master mode.

Select the receiver by pressing the  button until the desired receiver confirms.

All the following settings will then only be executed for this device.

	Open the shading solution to the upper limit position.
	Then re-press the programming button and also the STOP and UP buttons for approx. 5 seconds. ▷ The receiver confirms.

Fly screen protection function

If the fly screen protection function is activated (if available in the receiver), obstacle detection is activated after a revolution of the barrel of approx. 140° from the upper limit position. If the roller shutter curtain meets an opened fly screen door, the drive stops and returns to the upper limit position.

The fly screen protection function is deactivated on delivery.

Both limit positions must be set before the fly screen protection function can be activated.



When both or individual limit positions are deleted, this set function is deleted as well.

Activating/deactivating the fly screen protection function

Put the transmitter into master mode.

Select the receiver by pressing the  button until the desired receiver confirms.

All the following settings will then only be executed for this device.





▲	Open the shading solution to the upper limit position.
● + ■ + ▼ 	Then press the teaching button and also the STOP and UP buttons for approximately 5 seconds. ▷ The receiver confirms.

Activating/deactivating repeater mode

Put the transmitter into master mode.

Select the receiver by pressing the  button until the desired receiver confirms.

All the following settings will then only be executed for this device.

● + 	Press the programming button, and then the changeover button as well, keeping them pressed. The current repeater mode is displayed. Continue holding the buttons down for 5 seconds to change over.	
 / 	The receiver confirms.	
	1x	Repeater mode activated
	2x	Repeater mode deactivated

Reset the transmitter to the factory setting

Attention

If the transmitter is reset to factory settings, master mode will no longer give you access to the receiver or receivers in which the transmitter has been programmed. Please only make this setting when the batteries are new.

Open the cover of the battery compartment.

Take out the batteries.

Then reinsert the batteries in the correct orientation, and then within one second press the master button  for at least five seconds, until the transmitter confirms. The status LED flashes yellow while the command is being executed.



Lights up
green /
red

Action completed successfully (green) or not successfully (red).











If the master button  is released while the status LED is flashing yellow, the procedure is cancelled.

Clean-up function for B-Tronic products

All receivers that are programmed and no longer present can be cleared with the clean-up function.



The clean-up function is always applied to the selected channel. The switching commands sequence must be carried out in quick succession. B-Tronic products that were temporarily unreachable during the process should be reprogrammed.

 	Select the desired channel.
	Put the transmitter into master mode.
 1 second	Press the programming button for 1 second.
 1 second	Press the programming button again for 1 second.
 6 seconds	Press the programming button again for 6 seconds.
	The LED flashes yellow quickly for about 3 seconds, then changes to green.
	Now press the changeover button to leave master mode.

Changing batteries



You will find the appropriate battery type in the "Technical data" chapter.

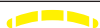

Flashes
yellow

If the status LED gives slow yellow flashes while the button is being pressed, the batteries are almost empty, and must be exchanged as soon as possible.

If the status LED no longer lights up when a button is pressed, the batteries are empty.

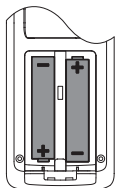

1. Open the cover of the battery compartment.
2. Take out the batteries.
3. Insert the new batteries correctly.
4. Close the cover of the battery compartment.

Wall bracket

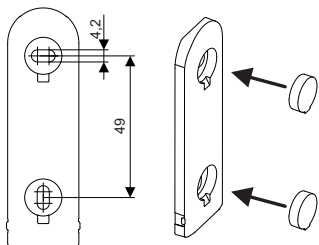

1. Check that the transmitter and receiver are working properly before mounting in the desired position.
2. Fasten the bracket to the wall using the two enclosed screws.
3. Now push the screw covers into the screw holes.

1. 2. 3.

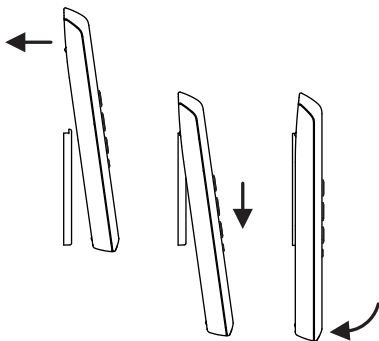

Cleaning



Only clean the device with a suitable cloth. Do not use aggressive cleaning agents that may damage the surface.



Technical data

Rated Voltage	3 V DC
Battery type	LR 03 (AAA)
Degree of protection	IP 20
Permissible ambient temperature	-10 to +55 °C
Maximum emitted transmission output	≤ 25 mW
Radio frequency	868.3 MHz
Max. number of receivers	32

The maximum transmitter range on and in the building is up to 25 m, and up to 350 m in the open.

What to do if...?

Problem	Remedy
Receiver is not responding. Receiver is not responding to the master button.	Insert new batteries.
	Insert batteries correctly.
	Reduce distance from receiver.
	Program transmitter.
	Check the receiver.
Status LED flashes yellow 	Insert new batteries.
Receiver does not run in a 24-hour rhythm.	Switch to  .
	Program switching times.
Run times deviate from those programmed.	Power failure at receiver. Re-program switching times.

Problem	Remedy
Status LED flashes red for 3 seconds  after operating one of the ▲, ■, or ▼ buttons.	Check the path for an obstacle.
Status LED lights up red for 3 seconds  after operating one of the ▲, ■, or ▼ buttons.	Reduce distance from receiver.
	Check the batteries.
	Check the power supply at the receiver.
Function cannot be set.	Check the functionality in the receiver.

Simplified EU declaration of conformity

Becker-Antriebe GmbH hereby declares that this radio control system complies with Directive 2014/53/EU.

The full text of the EU declaration of conformity is available at the following web address:

www.becker-antriebe.com/ce



Subject to technical changes without notice.



BECKER